



ROBOTICA MOBILE NELL'INTRALOGISTICA

VERSATILITA' E SCALABILITA' CON LIVEPICK E SMARTPOCKET

IL MAGAZZINO DEL FUTURO
MILANO - 23 APRILE 2026



TGW IN NUMERI



1969
FONDATA



4,600
FTE IN 2025



26
SEDI NEL
MONDO



1,07
MILIONI DI
VENDITA



100%
POSSEDUTA DA UNA
FONDAZIONE PRIVATA



3
I CORE BUSINESSES



PIU DI 3,000
CLIENTI NEL MONDO

Presenza locale in Italia



**Vicini ai nostri clienti, con le nostre persone!
Un Team Italiano di circa 150 dipendenti —
Da Sales a Realization al Life-Time Service**

- Sede a Spilamberto (MO)
- Fatturato: ~ 45 M€
- Installazioni: > 70 dirette
> 200 indirette
- Settori: Fashion, Grocery, Industrial&Consumer



OPERATIONS +
REALIZATION

35%

SALES
AMMINISTRAZIONE

15%

LIFETIME SERVICE

50%



150
dipendenti



A hand is shown typing on a laptop keyboard. The background is a dark, futuristic cityscape at night, overlaid with a network of glowing blue and orange nodes connected by thin lines. The overall aesthetic is high-tech and digital.

PERCHE' LA ROBOTICA MOBILE?

Presentazione TGW Italia, © 2025 TGW Logistics Group GmbH



LE SFIDE



Comportamento
dei consumatori
sempre più
imprevedibile



Avvento di
nuove
tecnologie



Tempi di
risposta
sempre più
brevi

BISOGNA ESSERE PRONTI A TUTTO



**“Non è la specie più intelligente a sopravvivere;
non è la specie più forte a sopravvivere. E’ quella
più capace di adattarsi al cambiamento”**

- Charles Darwin

LA DOMANDA DEI CONSUMATORI



Throughput (LC/h)

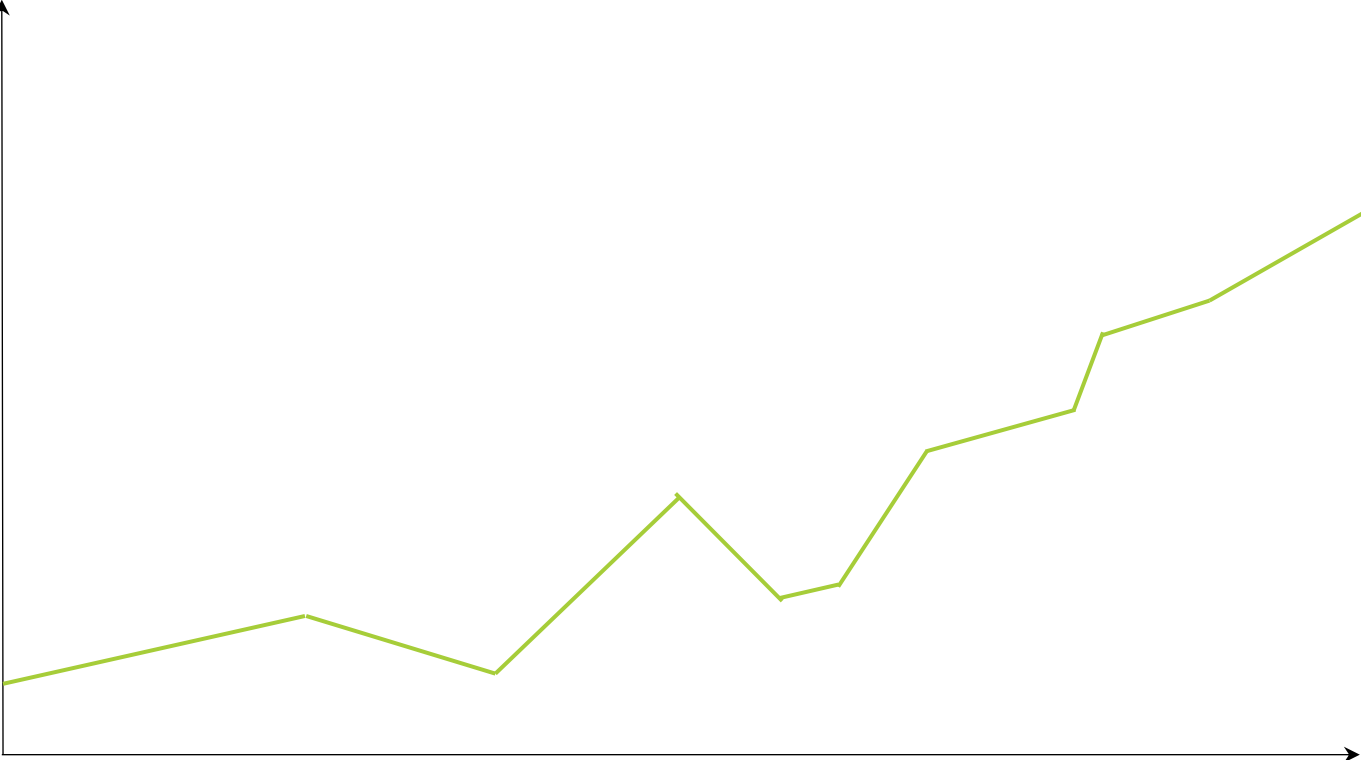

Time

ESPANSIONE A GRANDI STEP NECESSARIA VISIONE DI LUNGO TERMINI

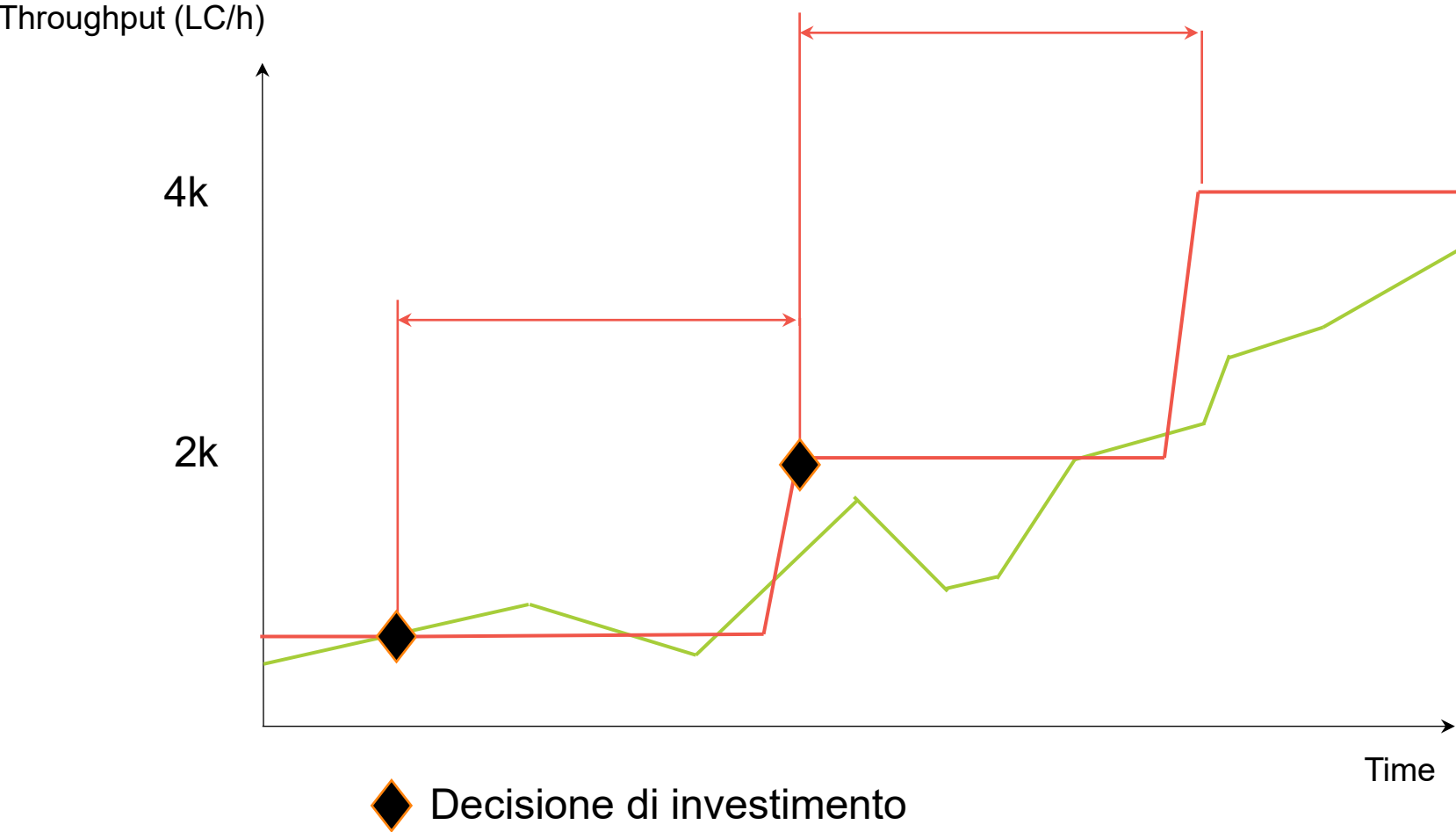

VISIBILITA' LUNGO TERMINE RIDOTTA

Throughput (LC/h)

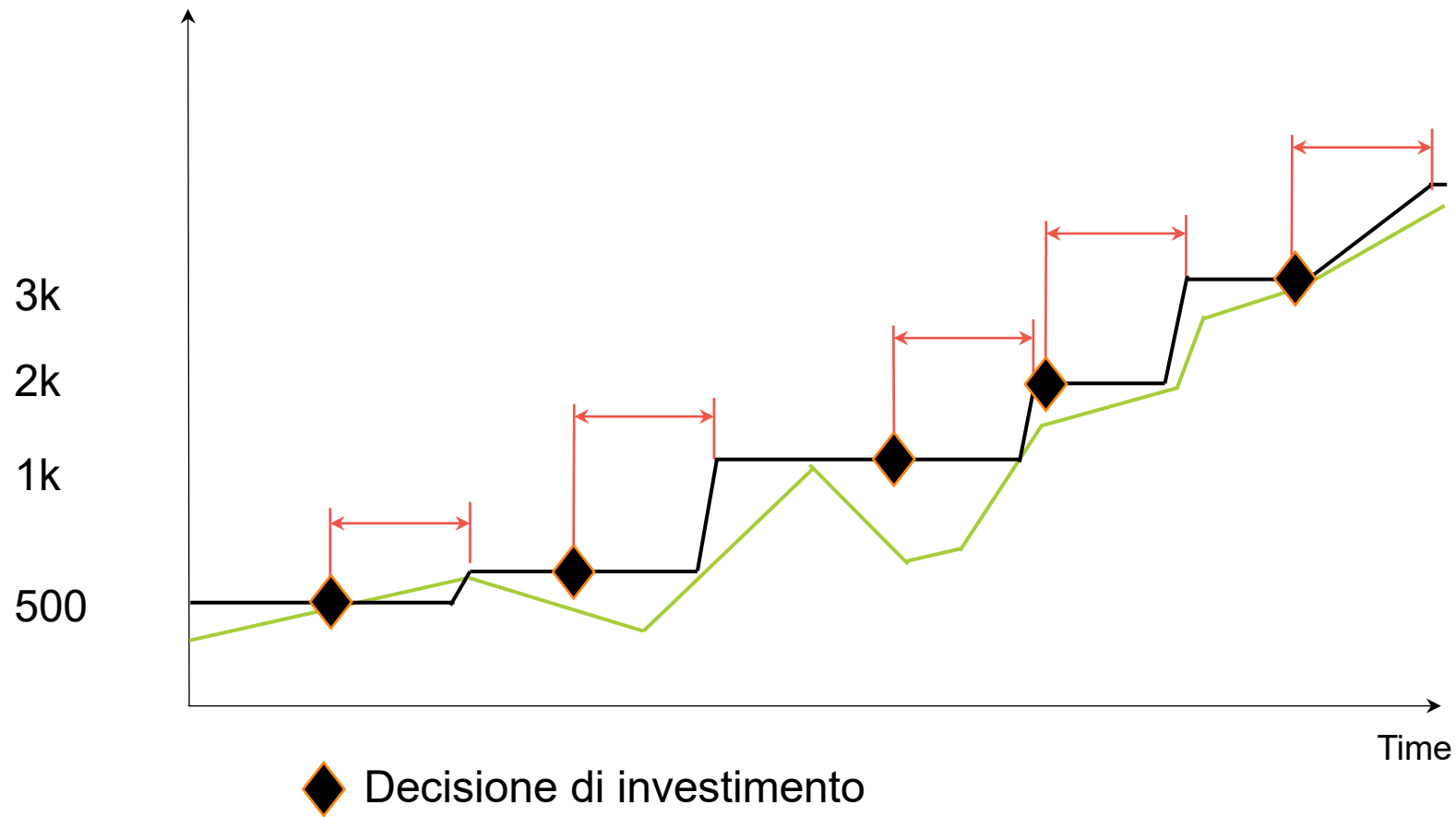



LA SOLUZIONE LIVEPICK

LIVEPICK®
ADAPTABLE ORDER FULFILMENT SYSTEM by TGW

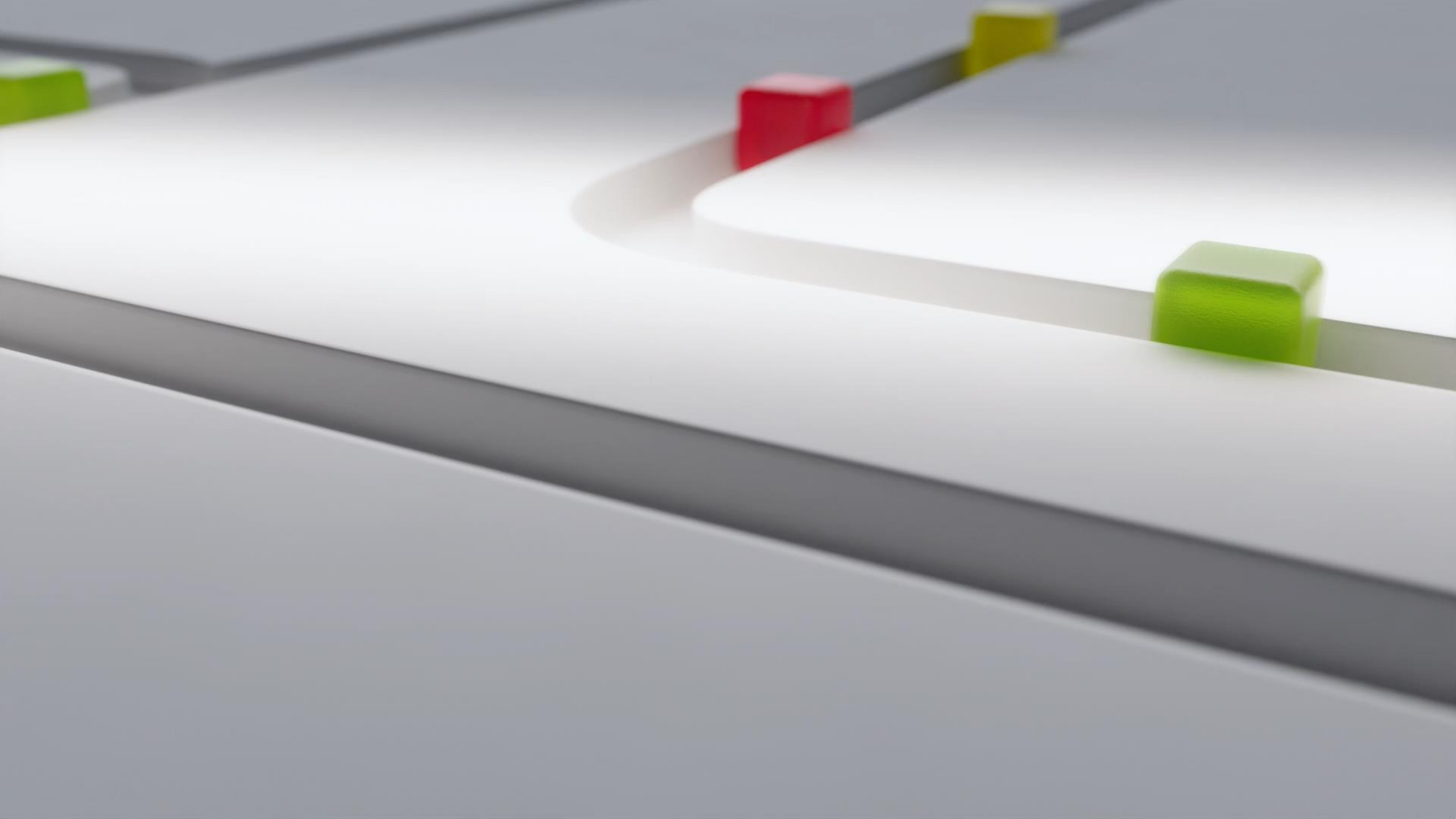

SORGENTE & TARGET (OPZIONE)

» Scaffale magazzino

» Climbing robots mobili

» Sistema di guida robots mobili

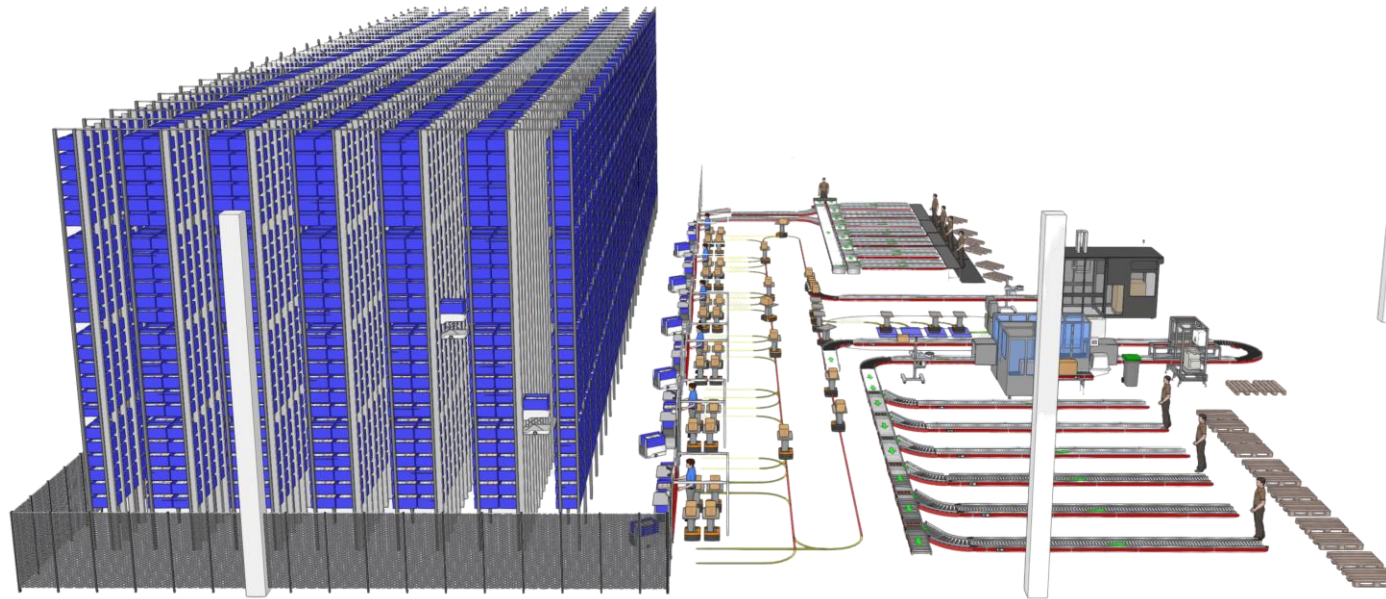

Stazioni di picking 1:4

Sequenza target fatta con AGVs

Sistema di trasporto targets (vuoti e pieni)

LIVEPICK - I MODULI



Engine Rack



"Climber" bot



one-to-four
picking workstations



"Runner" Bot



Equivale a

ORDER FULFILMENT

LIVEPICK - SCAFFALATURA

Densità di stoccaggio ottimizzata

- Fino a 12 m di altezza.
- Stoccaggio in singola e doppia profondità.
- Stoccaggio netto superiore a 90%.

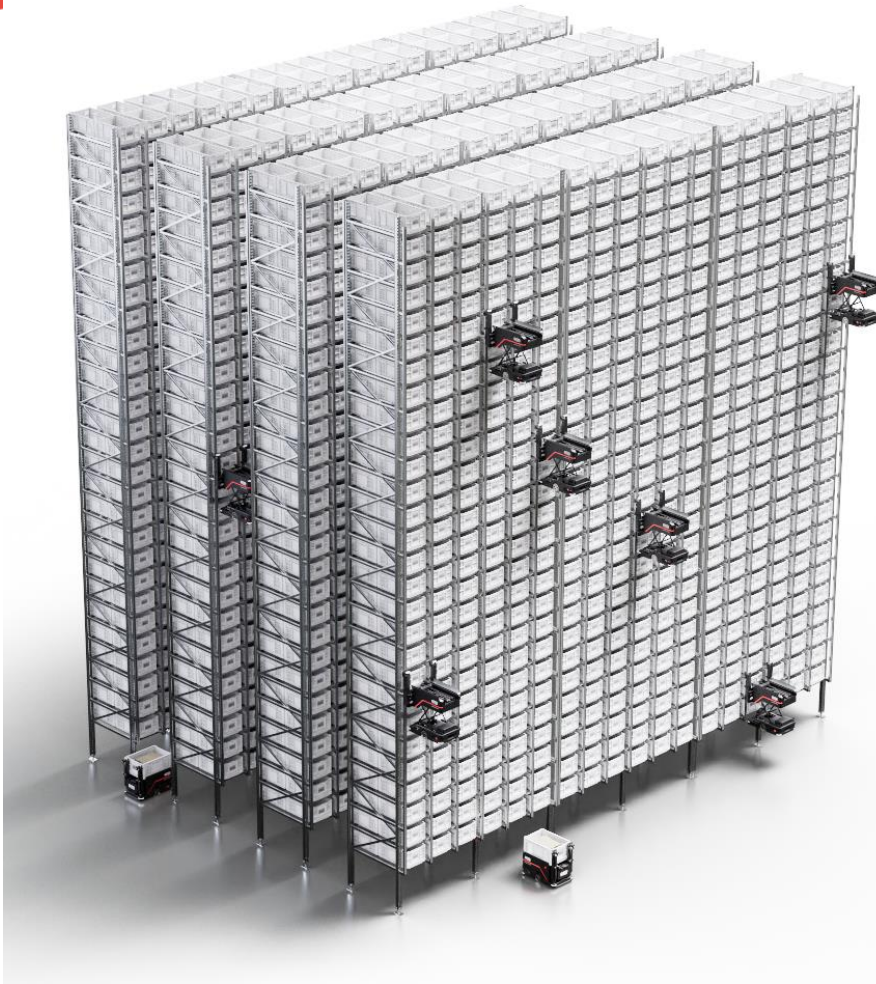

Simple rack = Simple floor

- Innovativo sistema di arrampicata su singolo lato.
- Bracci robotici mobile si adattano alla scaffalatura.
- Tolleranza ridotta per la posa della soletta e l'installazione delle scaffalature.



LIVEPICK - IL CLIMBER BOT



- Velocità orizzontale: 4 m/s
- Velocità verticale: 1 m/s
- Load capacity: 30kg



LIVEPICK - PICKING STATION - LATO SORGENTE



Massima sicurezza

Picking direttamente dal robot



Alta velocità

LIVEPICK - PICKING STATION - LATO TARGET



Picking on fast-moving bots

- Scalabilità sul lato ordini
- Flessibilità sul profile ordine, regolando il numero di robots
- Pick-to-light technology - alta affidabilità
- Massima ergonomia della stazione
- Tutti gli accessori a portata di mano alla stazione
- Bassa distanza tra sorgente e target - prestazioni di picking fino a 350 t/h

LIVEPICK – IL RUNNER BOT



Gestione cartoni ordine

- Robots semplice per gestire gli ordini
- Possibilità di pick&pack – diverse dimensioni colli
- Carico/scarico automatico

**DISCOVER
SMARTPOCKET**

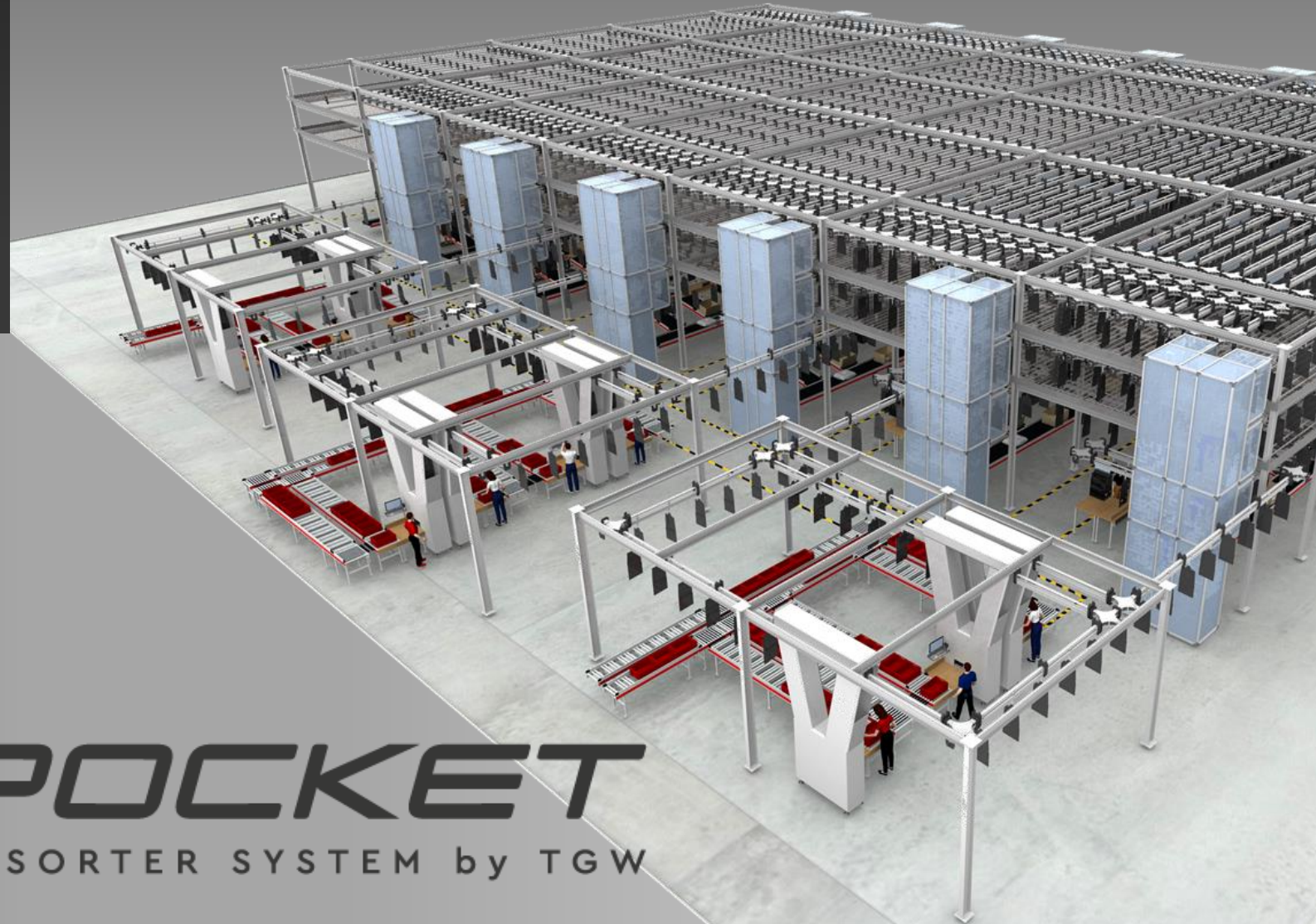

SMARTPOCKET
REVOLUTIONARY POCKET SORTER SYSTEM by TGW

SMARTPOCKET - I COMPONENTI

Carrier

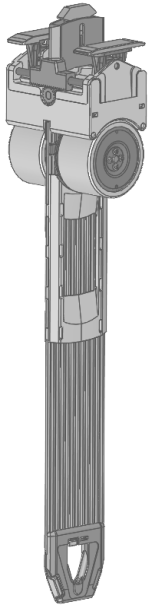

Rail

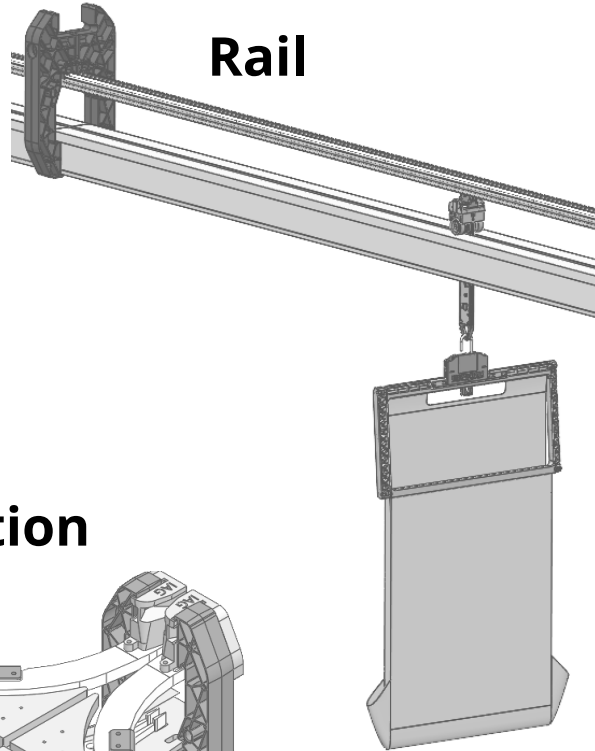

Junction

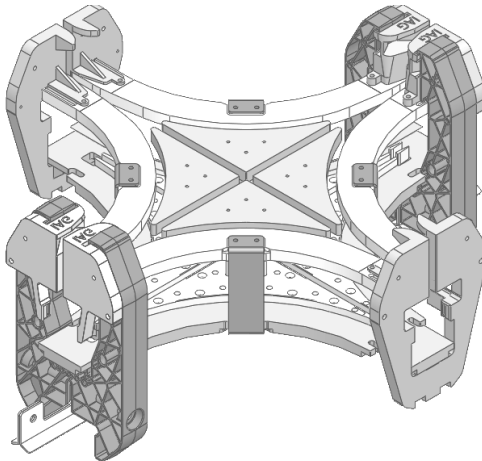

Paternoster

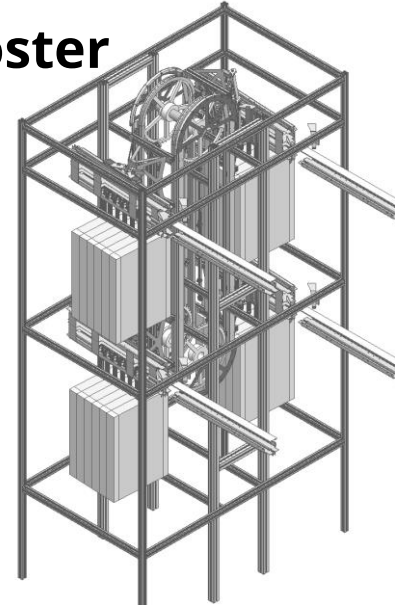

Lift

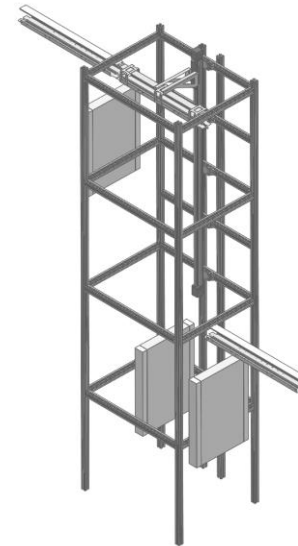

Workstations

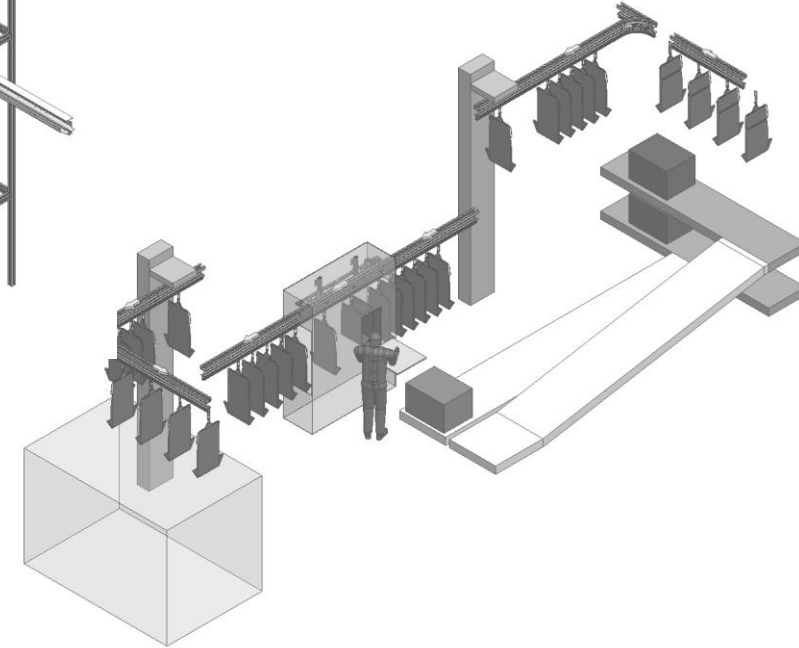

POCKET SORTER TRADIZIONALE

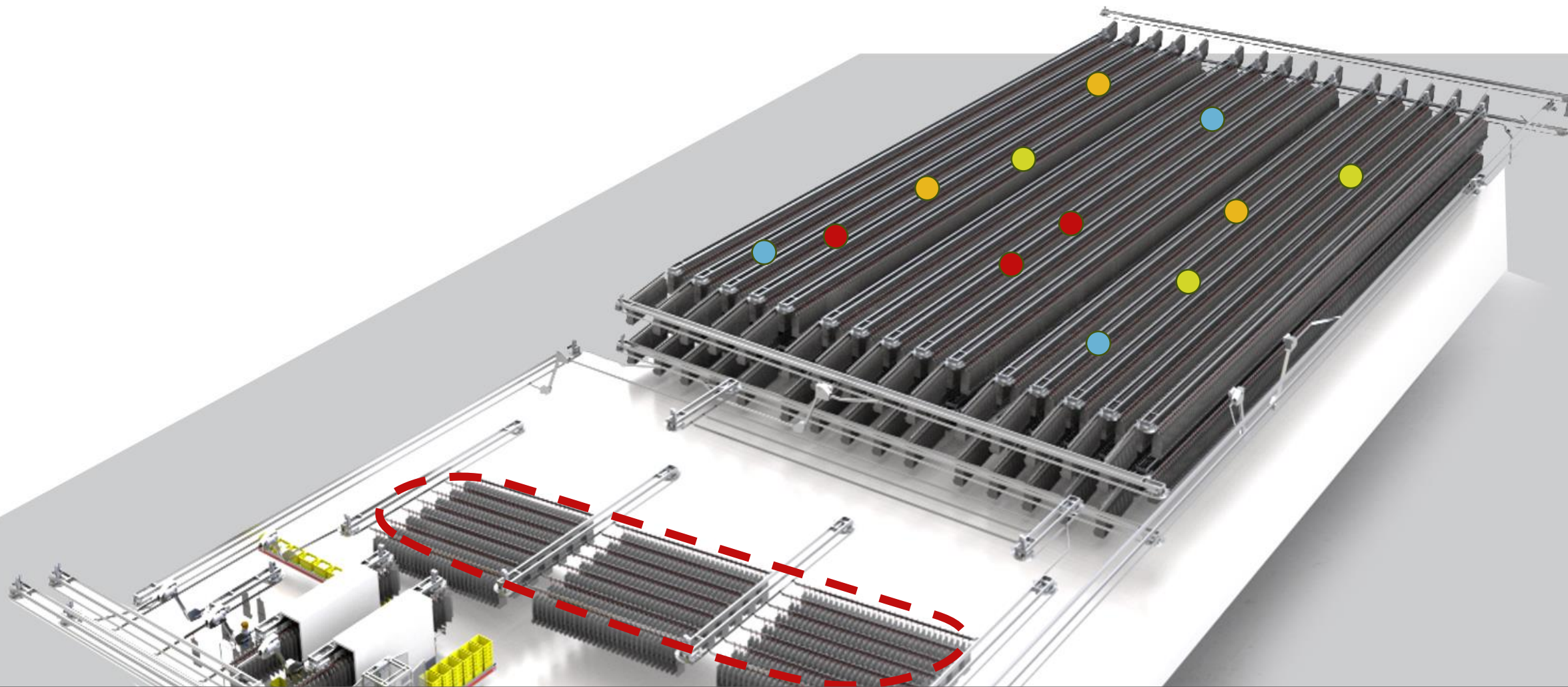

TGW SMARTPOCKET

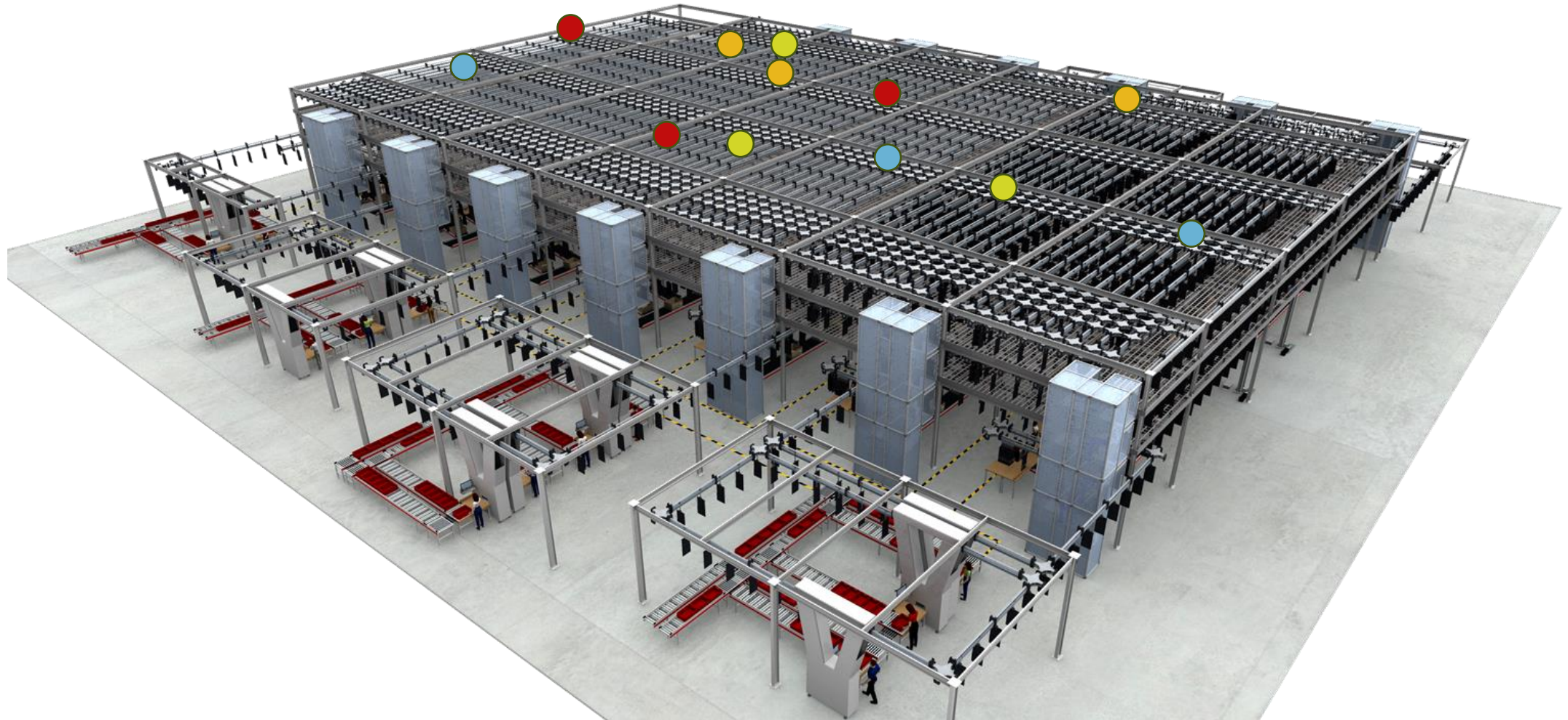

IL CARRIER



500 x 380 x 150 mm

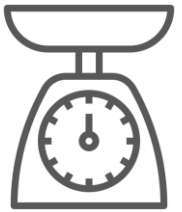

3 kg



PLUG&PLAY PROCESS + INTELLIGENT POCKETS



- Combined Buffer and Sort modules
- Passive Tracks
- Induct workstations
- Packing workstations



Free-Scalable
system

Intelligent, self-
driven Pockets

= **SCALABLE BUSINESS**

PLUG&PLAY PROCESS + INTELLIGENT POCKETS



- Combined Buffer and Sort modules
- Passive Tracks
- Induct workstations
- Packing workstations

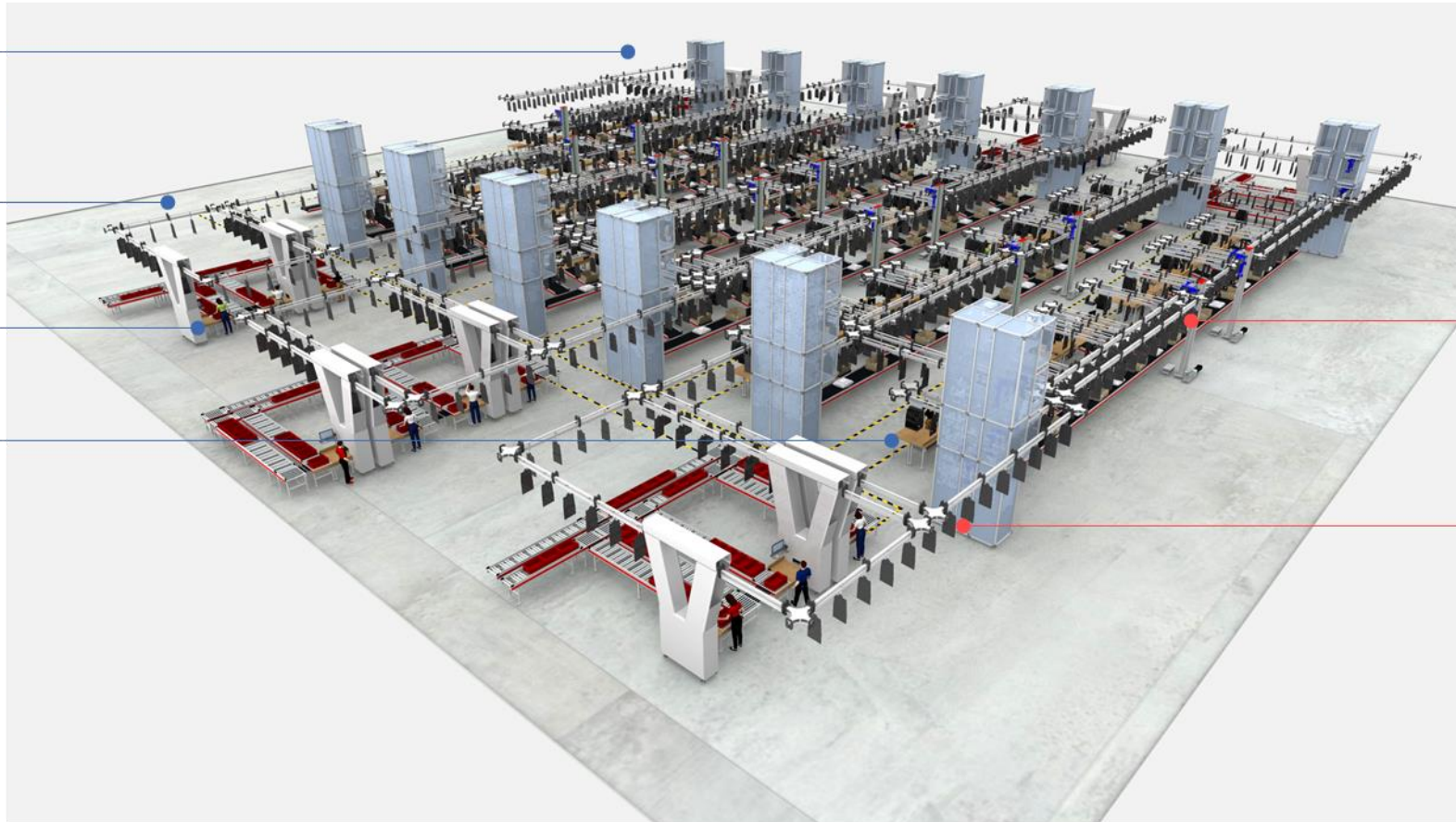

Free-Scalable
system

Intelligent, self-
driven Pockets

= **SCALABLE BUSINESS**



RFID: 1000 items/h

ZERO TOUCH OPERATION

Caricamento tasca automatico

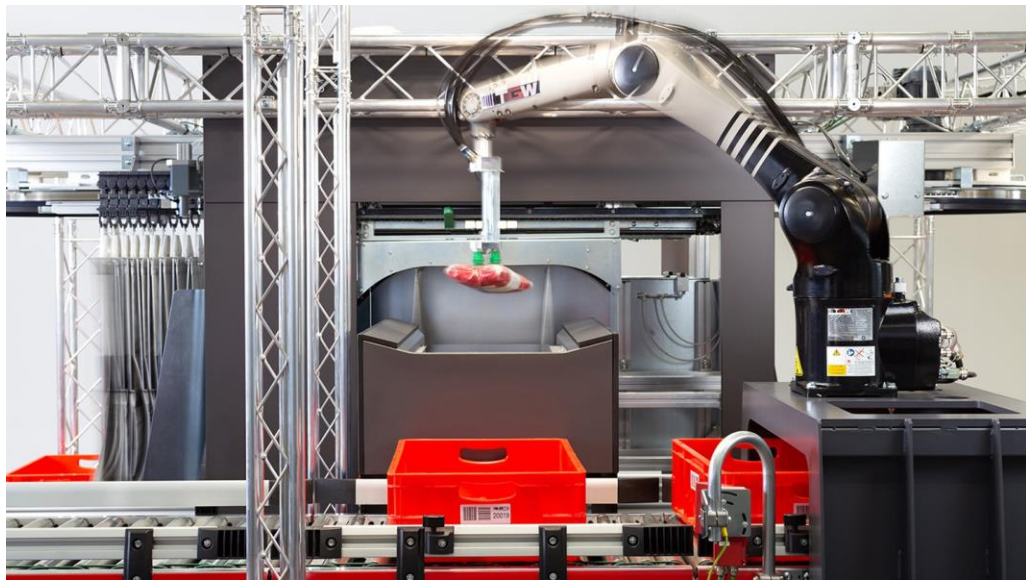

Scaricamento tasca automatico

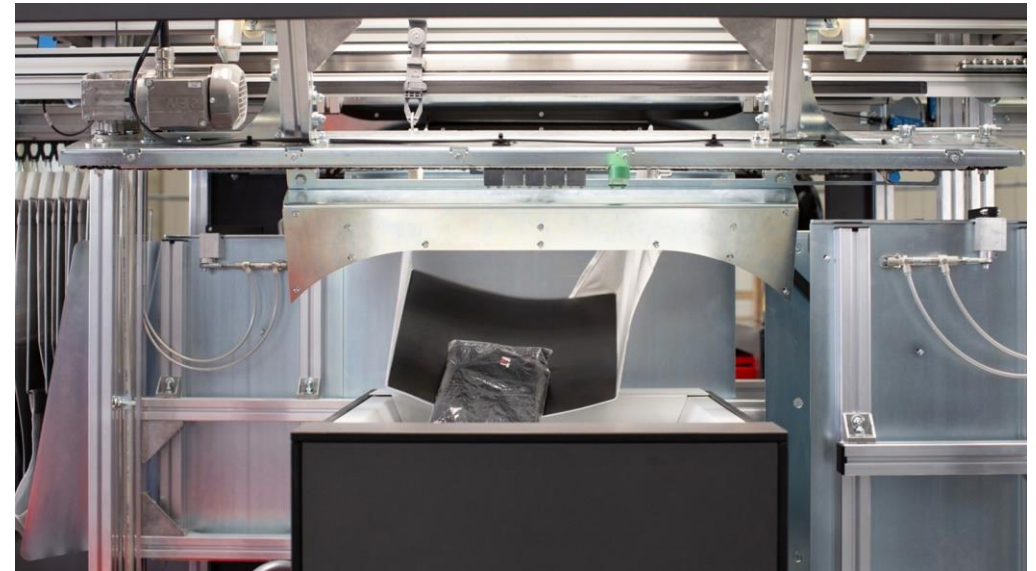

SMARTPOCKET – IL VIDEO

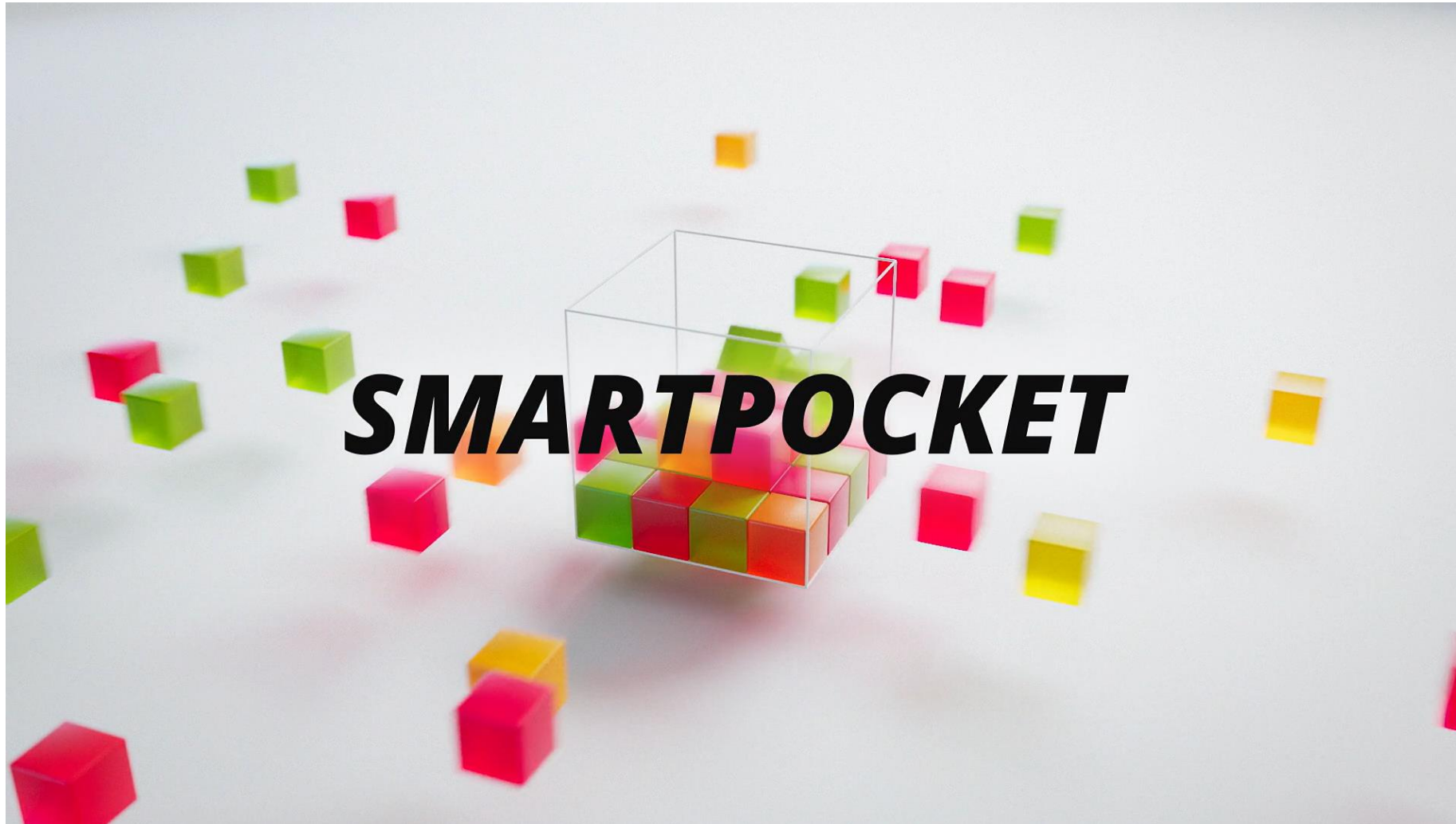

A photograph of a modern building's glass entrance. A woman in a light green jacket and a man in a light blue blazer are standing on the steps leading up to the glass doors. The building has a grey facade and is flanked by green trees.

GRAZIE. Grazie per l'attenzione
Andrea Pezzei
Cell. +39 3407152892